

SECTION A
GLASS NOT SHOWN

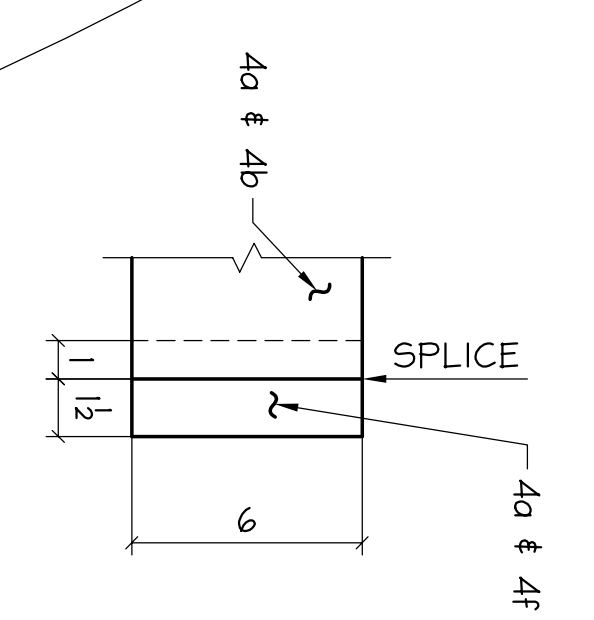

VIEW B

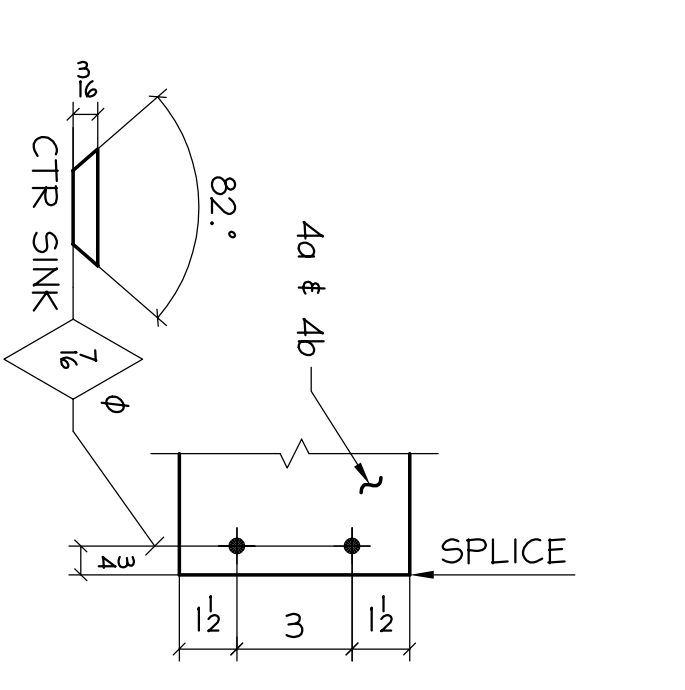

VIEW C

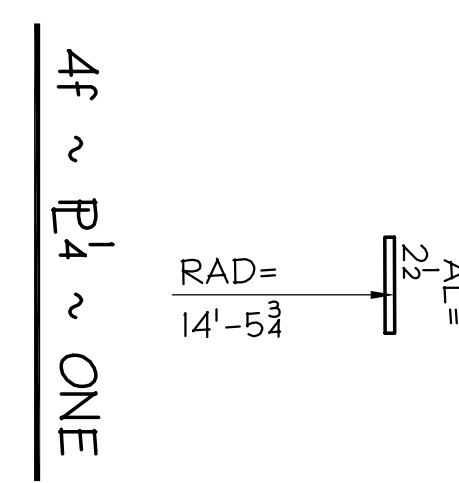
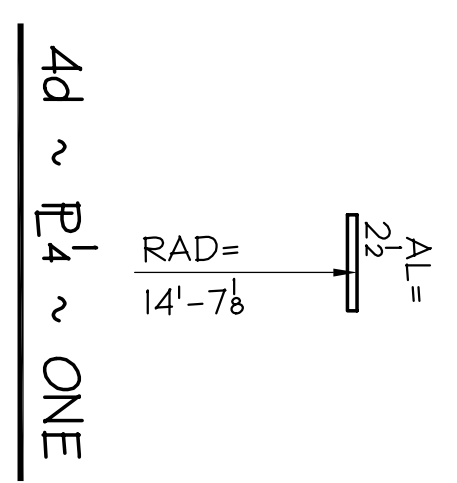

| NO. TO SHIP | TOTAL | PCS | DESCRIPTION | LENGTH | REMARKS | UNIT | WEIGHT |
|-------------|-------|-----|----------------------|---------|--------------------|------|--------|
| MARK | MARK | | | FT. IN. | | | TOTAL |
| ONE SPA-4 | ONE | 4a | R4 X 6 | 11 | 3 1/8 AS6 - ROLLED | | |
| | ONE | 4b | R4 X 6 | 11 | 0 3/8 AS6 - ROLLED | | |
| | 5 | c | R4 X 1 1/2 | 0 | 1 1/8 AS6 | | |
| | ONE | 4d | R4 X 2 1/2 | 0 | AS6 - ROLLED | | |
| | ONE | 4f | R4 X 2 1/2 | 0 | AS6 - ROLLED | | |
| | | | FIELD HARDWARE | | | | |
| | 9 | b1 | 1/2" SS CAP SCREW | 0 | TCR40244A513 | | |
| | 9 | b2 | 1/2" SS ACORN NUT | 0 | TCR41855A370 | | |
| | 10 | b3 | 1/2" SS FLAT WASHER | 0 | TCR41950A030 | | |
| | 9 | b4 | 1/2" NYLON BUSHING | 0 | TCR4389K346 | | |
| | 4 | b5 | 1/2" SS MESH SCREW | 0 | TCR41771A619 | | |
| | | b6 | 1/2" GASKET MATERIAL | 22 | 4 LIN. FT. | | |

FABRICATION NOTES:

HOLES UNO: 5/8"

WELD:

REF DWG: DE-1A

MATERIAL UNO: LAMINATED GLASS

PAINT: Copper Penny - 810-8

NOTES:

VERIFICATION OF DIMENSIONS, DETAILS, AND ETC. ARE REQUESTED, WHERE INDICATED, IF EACH VERIFICATION IS NOT NOTED OTHERWISE. IT WILL BE ASSUMED TO BE CORRECT AS SHOWN.

FOR FABRICATION

FOR PURCHASING

FOR APPROVAL

DATE

DATE

DESIGNER: Design Trends, Inc.

CONTR: Gilbane Building Co.

SAVOY STUDIOS

ART GLASS RIBBON SCULPTURE

GALVESTON, TX

611 N TILLAMOOK ST PORTLAND, OR 97227

Phone: 503.282.5095 FAX: 282.2183

ADJ. / ANGLE DETAILING, INC.

ADJ. JOB# 2003-265

DRAWN BY: KP

CHKD BY: ADI

JOB NO. 02-178

DWG. NO. spc-4

BILL OF MATERIAL