

email: info@angledetailing.com

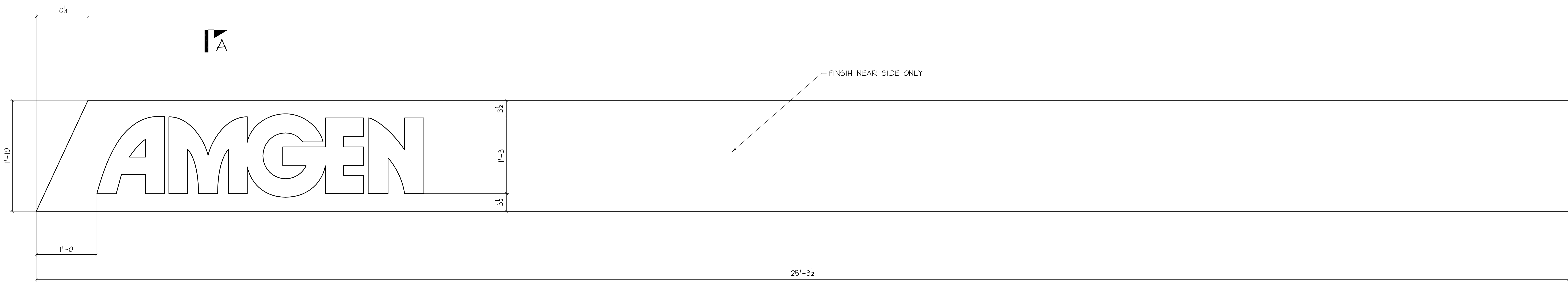

ONE ~ ENTRY MARKER LOGO  $\mathbb{P}$  ~ X3A

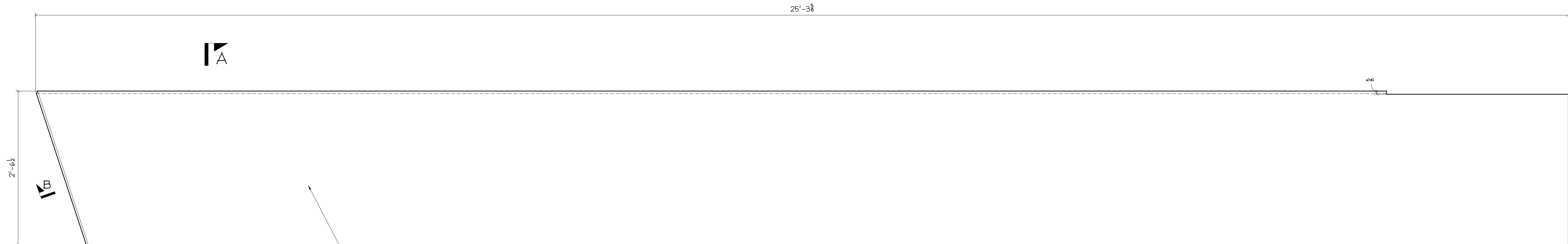

ONE ~ BACK  $\mathbb{P}$  ~ X3B

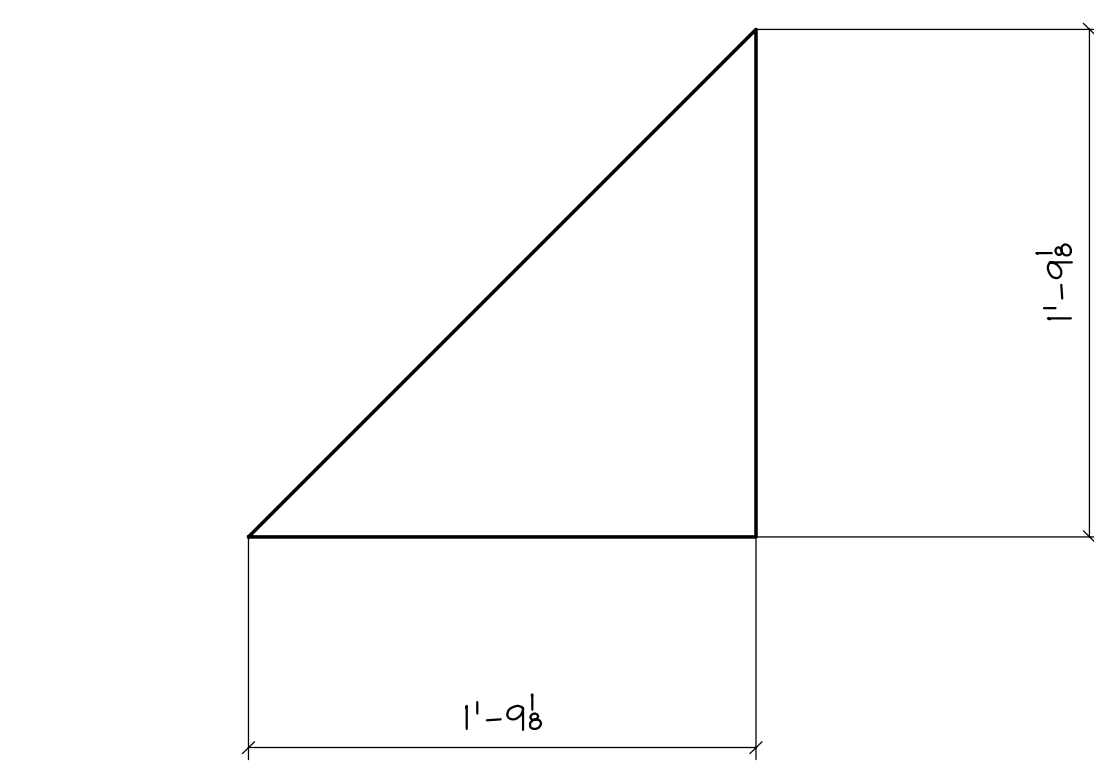
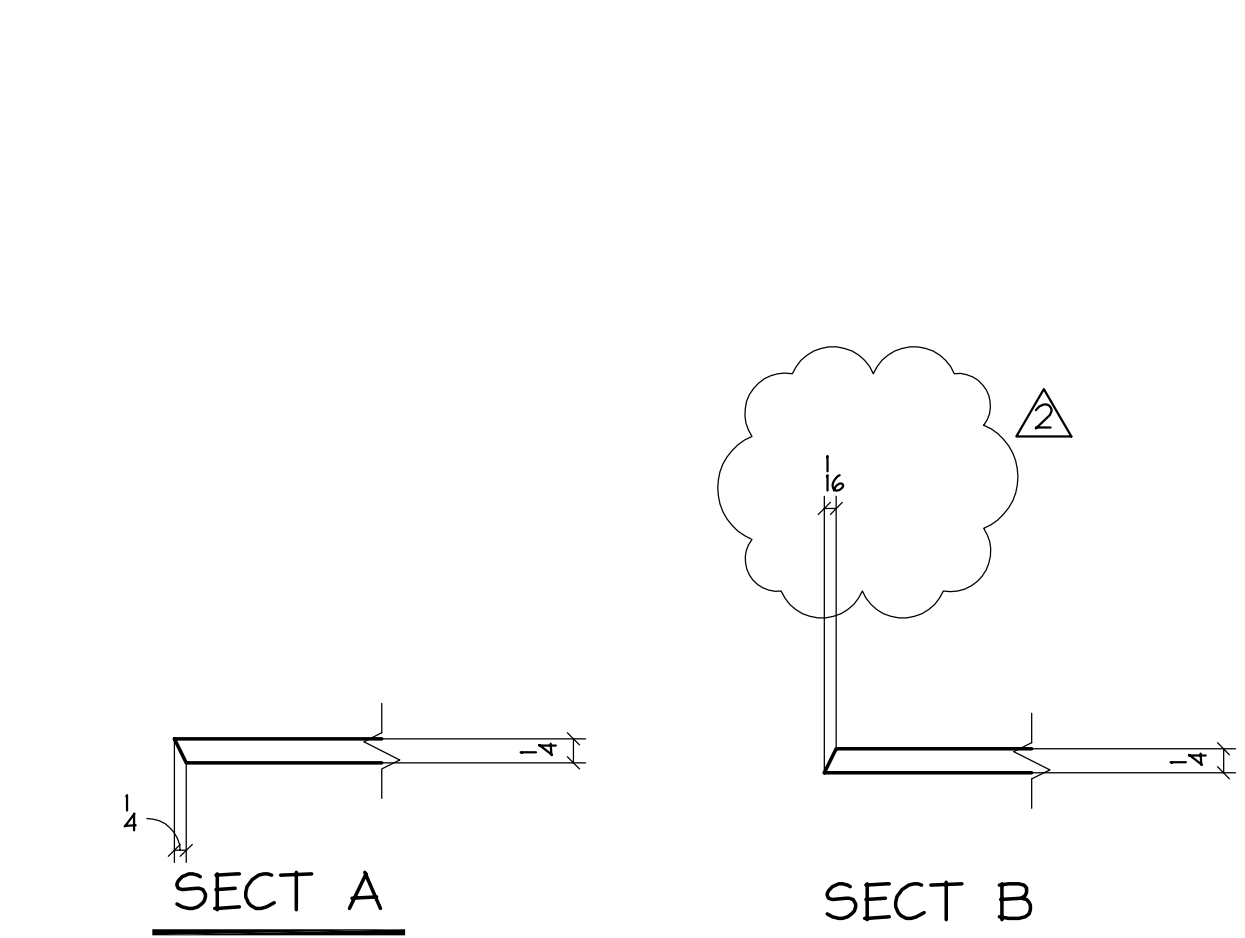

ONE ~ INTERNAL STIFFENER ~ X3C  
NO FINISH

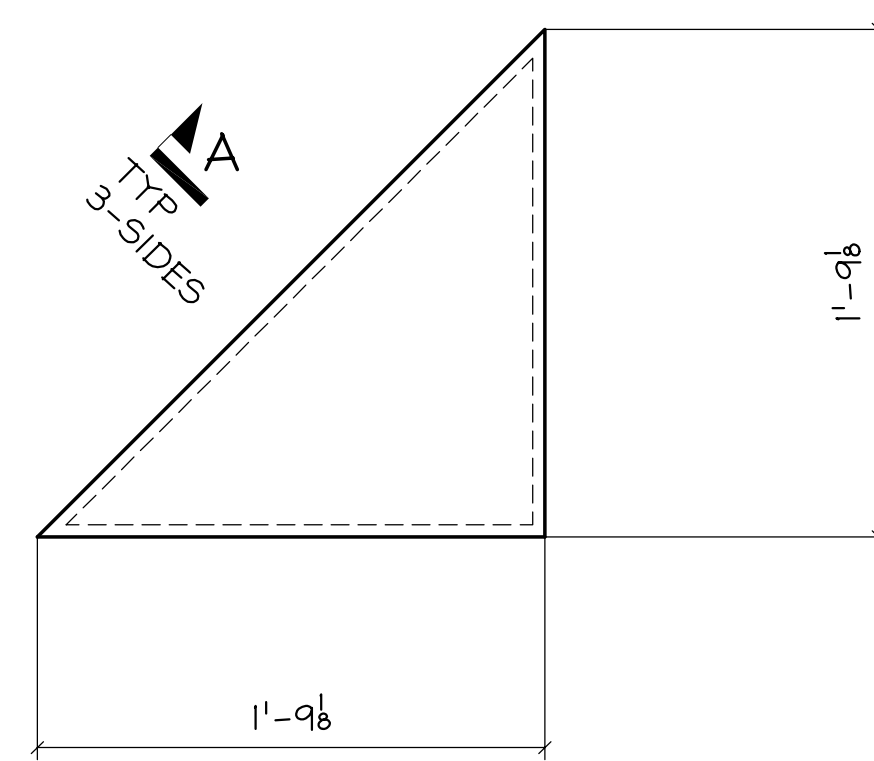

ONE ~ END CLOSURE ~ X3D  
NO FINISH

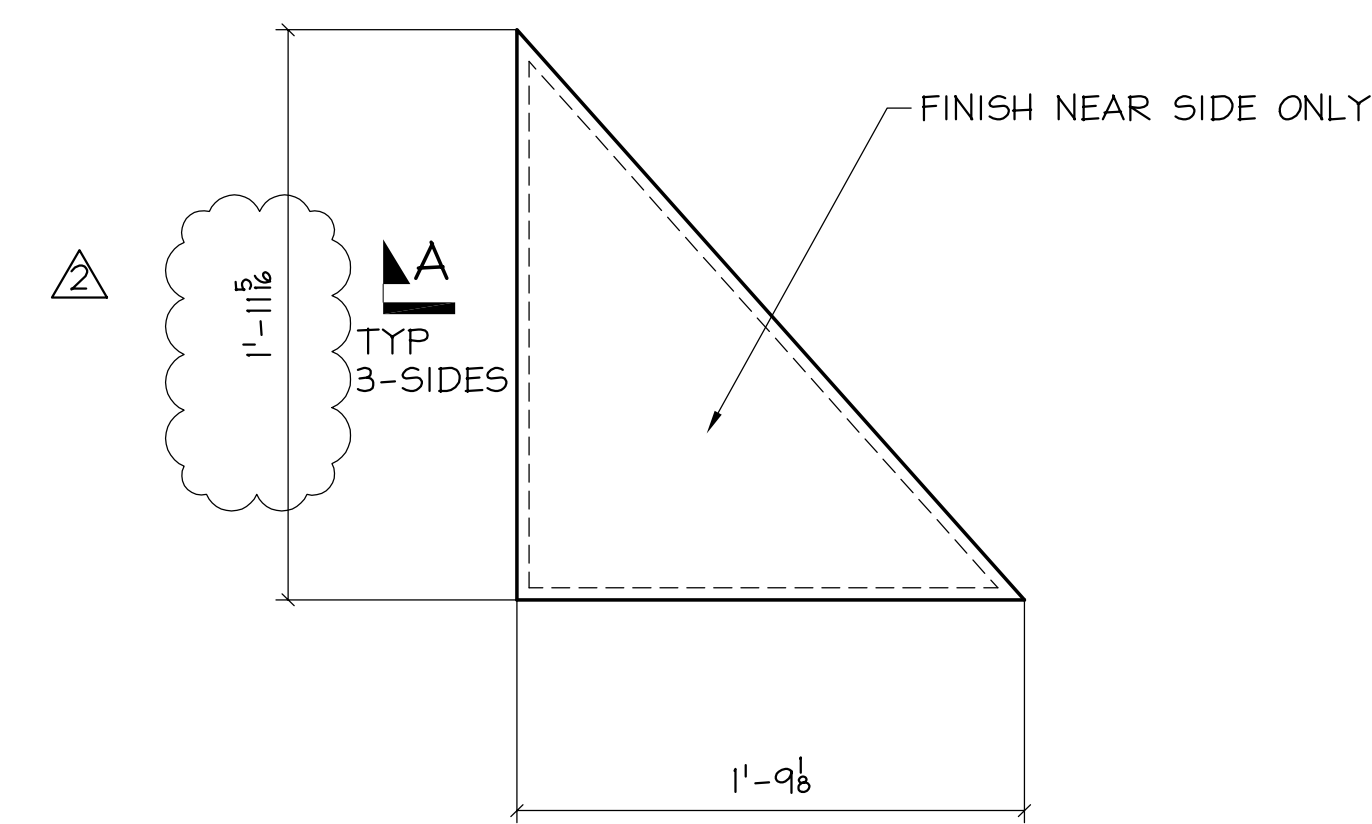

ONE ~ END CLOSURE ~ X3F

BILL OF MATERIAL

BILL OF MATERIAL

NO.	SHIP MARK	TOTAL	PIC MARK	DESCRIPTION	LENGTH		REMARKS	ADV. BIL.	WEIGHT		NO.	SHIP MARK	TOTAL	PIC MARK	DESCRIPTION	LENGTH		REMARKS	ADV. BIL.	WEIGHT			
					FT.	IN.			UNIT	TOTAL						FT.	IN.			UNIT	TOTAL		
	1	X3A	$\mathbb{P}$ 4 x 22	25	3 1/2																		
	1	X3B	$\mathbb{P}$ 4 x 30 1/2	25	3 3/8																		
	1	X3C	$\mathbb{P}$ 4 x 21 1/8	1	9 1/8	NO FINISH																	
	1	X3D	$\mathbb{P}$ 4 x 21 1/8	1	9 1/8	NO FINISH																	
	1	X3F	$\mathbb{P}$ 4 x 21 1/8	1	11 1/8																		

**FABRICATION NOTES:**

HOLES UNO:  
 WELD:  
 REF DWG: I  
 MATERIAL UNO: GRADE 304 STAINLESS

PAINT:

NOTES: FINISH: RANDOM ORBITAL (UNO)  
 W/ CLEAR COAT

VERIFICATION OF DIMENSIONS, DETAILS, AND ETC. ARE REQUESTED, WHERE INDICATED. IF EACH VERIFICATION IS NOT NOTED OTHERWISE, IT WILL BE ASSUMED TO BE CORRECT AS SHOWN.

REV	DATE	BY	DESCRIPTION	DWG STATUS	DATE
2	11/11/03	ga	update dimension and size X3F	FOR FABRICATION	
1	11/10/03	GA	UPDATE FINISH & LOGO / ISSUE FOR FABRICATION	FOR PURCHASING	

**HELIX PROJECT**  
 ENTRY MARKER  
 SEATTLE, WASHINGTON

ENGR: **kpff** / ADI / ANGLE DETAILING, INC.  
 CONTR: / ADI JOB # 2003-317

**COLUMBIA WIRE & IRON WORKS**  
 5555 N. Channel Portland, Ore. 97217  
 www.cwiil.com/503-286-6600

DRAWN BY: **ga** / CHKD BY: **GBA** / JOB NO: **670020XX** / DWG. NO: **3**

A:\2003-317\ADI\_SUBMITTALS-REC036-11221003-CURRENT\3.DWG 12/24/03 9:43am E:\BPA\_email