

BILL OF MATERIAL

NO. TO SHIP	SHIP MARK	TOTAL NO. PC.	PC. MARK	DESCRIPTION	LENGTH		REMARKS	ADV. BILL	WEIGHT	
					FT.	IN.			UNIT	TOTAL
ONE	e9			PL 1/2 x 19 1/2	34	1 1/2				

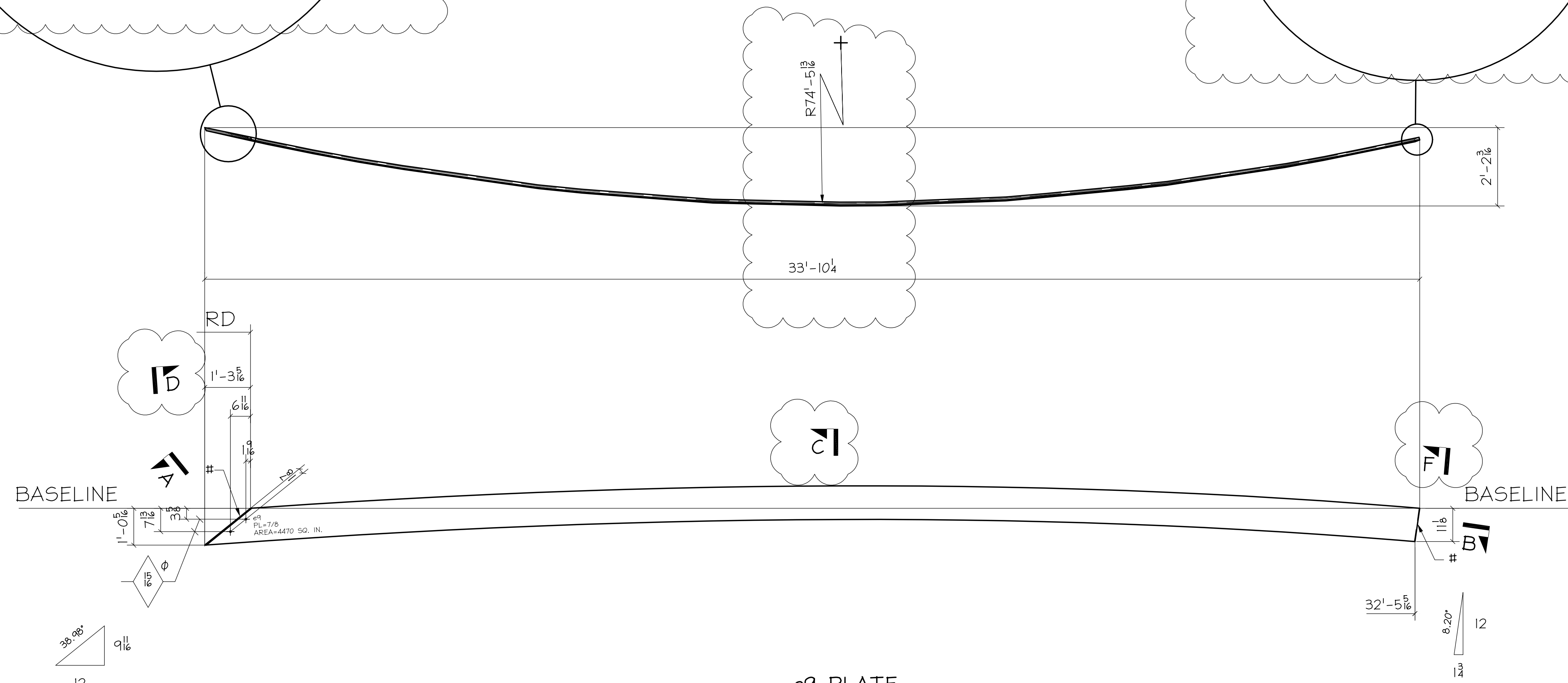

e9 PLATE

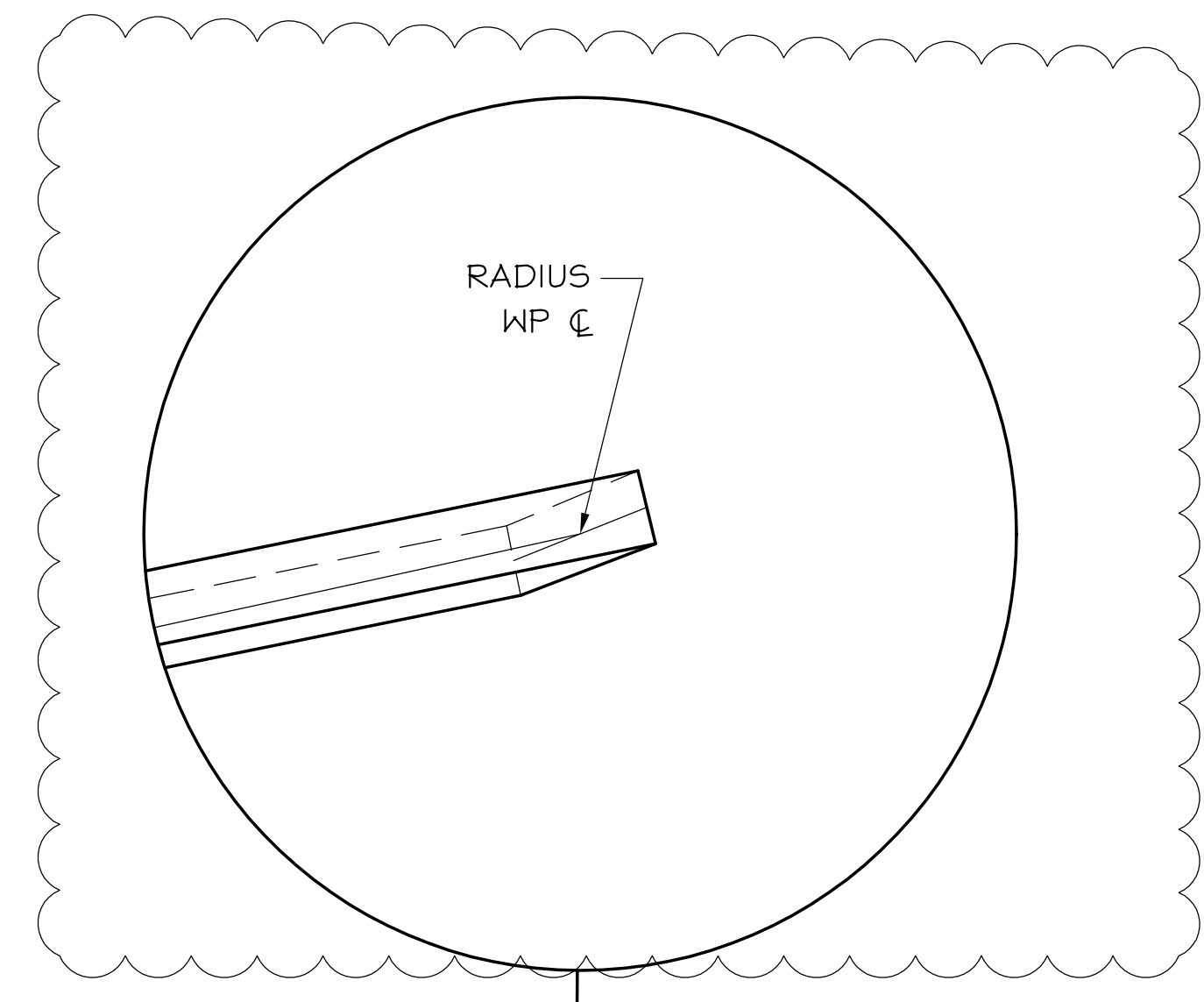
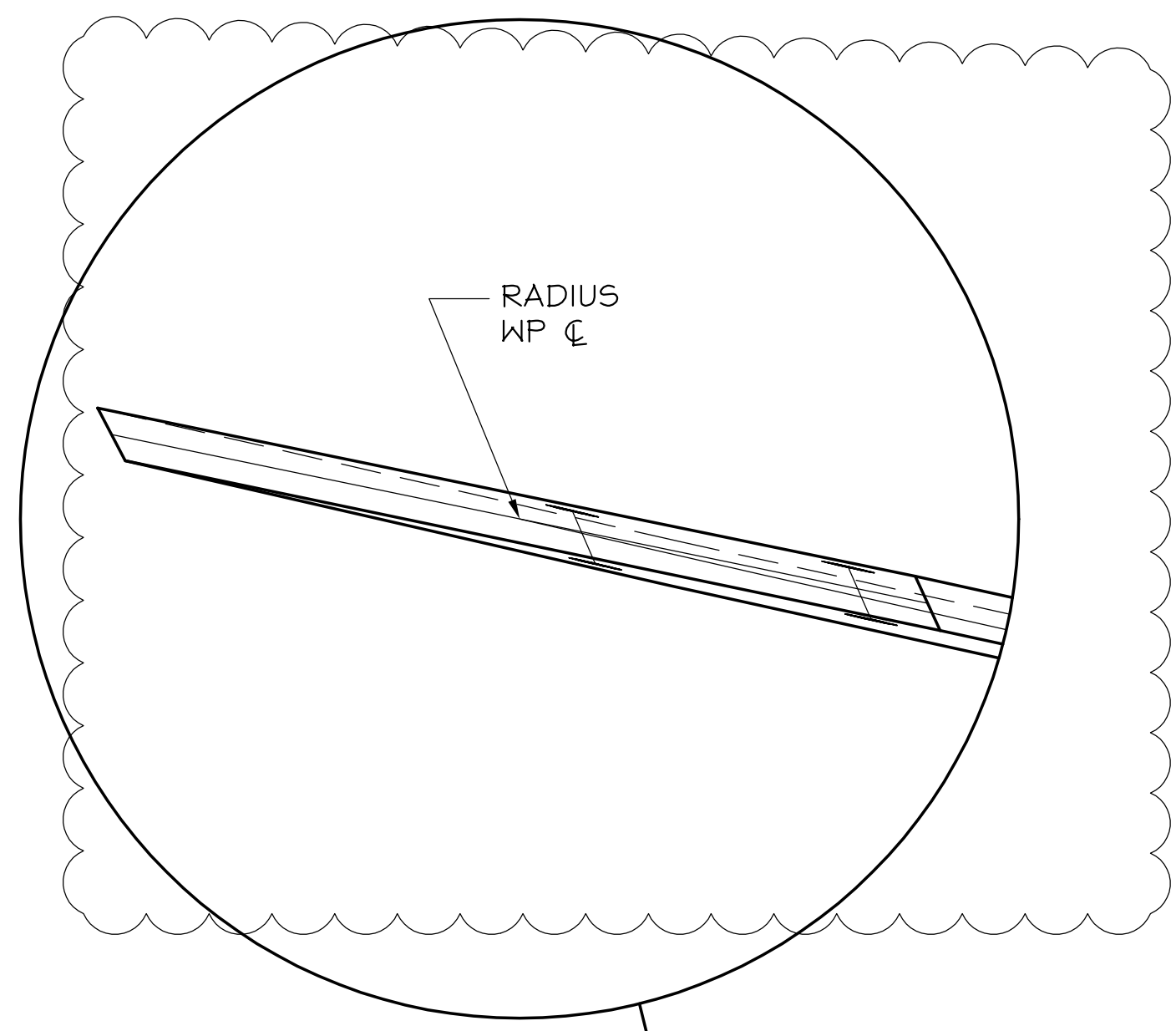
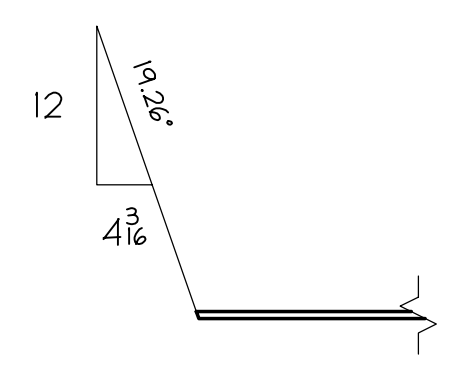
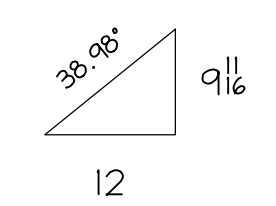

SECTION A

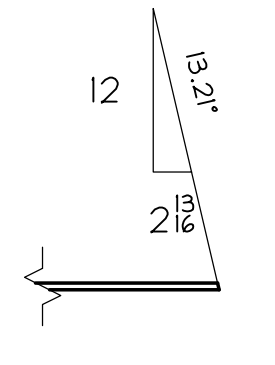

SECTION B

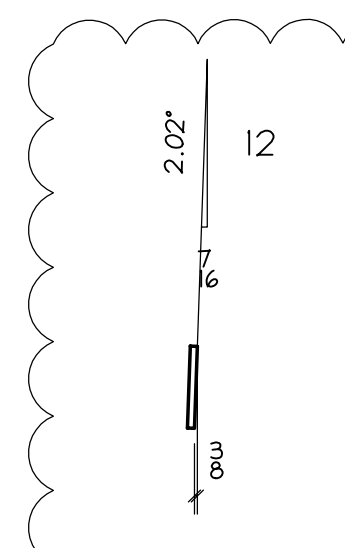

SECTION C

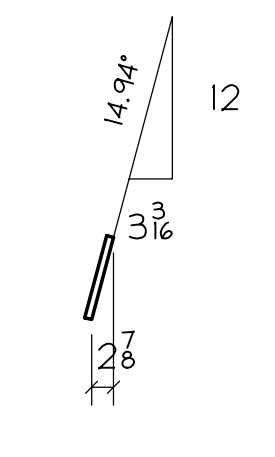

SECTION D

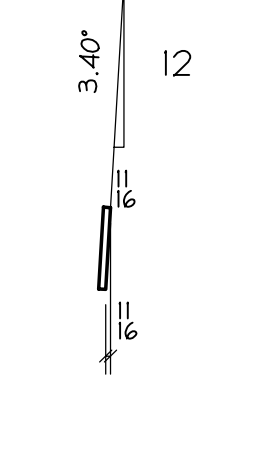

SECTION F

- \* = SCRIBES FOR NEAR SIDE OUTLINE OF X-BRACE PLATES
- \*\* = SCRIBES FOR FAR SIDE  $\phi$  OF X-BRACE PLATES
- \*\*\* = SCRIBES FOR NEAR & FAR SIDE X-BRACE PLATES
- FAR SIDE PLATES ARE SCRIBED ON NEAR SIDE WITH "X" AND LINES
- RECTANGLES WITH "X" IN EACH CORNER REPRESENT FS SHEAR  $\phi$
- DRILL 1/8" HOLES AT ALL "X" TO TRANSFER LOCATIONS TO FAR SIDE
- # = PREP FOR SHOP CP WELD AFTER DXF BURN
- ⊗ = NEAR SIDE TARGETS
- ⊙ = FAR SIDE TARGETS

FABRICATION NOTES:	
HOLES UNO: 1/2 $\phi$	
WELD: E70XX	
REF DWG: E3	
MATERIAL UNO: A36	
TS=A500 GRB	
PAINT: NO PAINT	
NOTES:	VERIFICATION OF DIMENSIONS, DETAILS, AND ETC. ARE REQUESTED, WHERE INDICATED. IF EACH VERIFICATION IS NOT NOTED OTHERWISE, IT WILL BE ASSUMED TO BE CORRECT AS SHOWN.

REV	DATE	BY	DESCRIPTION	DWG STATUS	DATE
B	12/10/01	WT	ADDED MARK AND SECTIONS	FOR FABRICATION	
A	11/30/01	WT	For Approval	FOR PURCHASING	

**JL PROPERTIES**  
 ASRC CANOPY  
 ANCHORAGE, ALASKA

**NORDAHL METALFAB**  
 14053 Pioneer Way East Puyallup, WA 98372  
 Phone: (253) 845-3201 FAX: (253) 845-2272

ENGR: BBFM      CONTR: DAVIS CONSTRUCTORS      ADI / ANGLE DETAILING, INC.      ADI JOB# 2001-146  
 DRAWN BY: CWL      CHKD BY: TCN      JOB NO. 1158      DWG. NO. 9-E/E